

©2001 James Industries, Inc. All rights reserved.
No part of this publication may be reproduced in whole or in part,
stored in a retrieval system, or transmitted in any form or by any means,
electronic, mechanical, photocopying, recording or otherwise, without
written permission from the publisher.

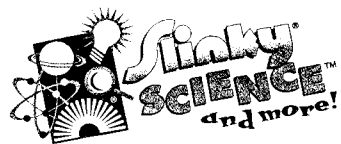

For more information about
permission, write to:
Slinky Science, PO Box 701394
Plymouth, MI 48170-0964

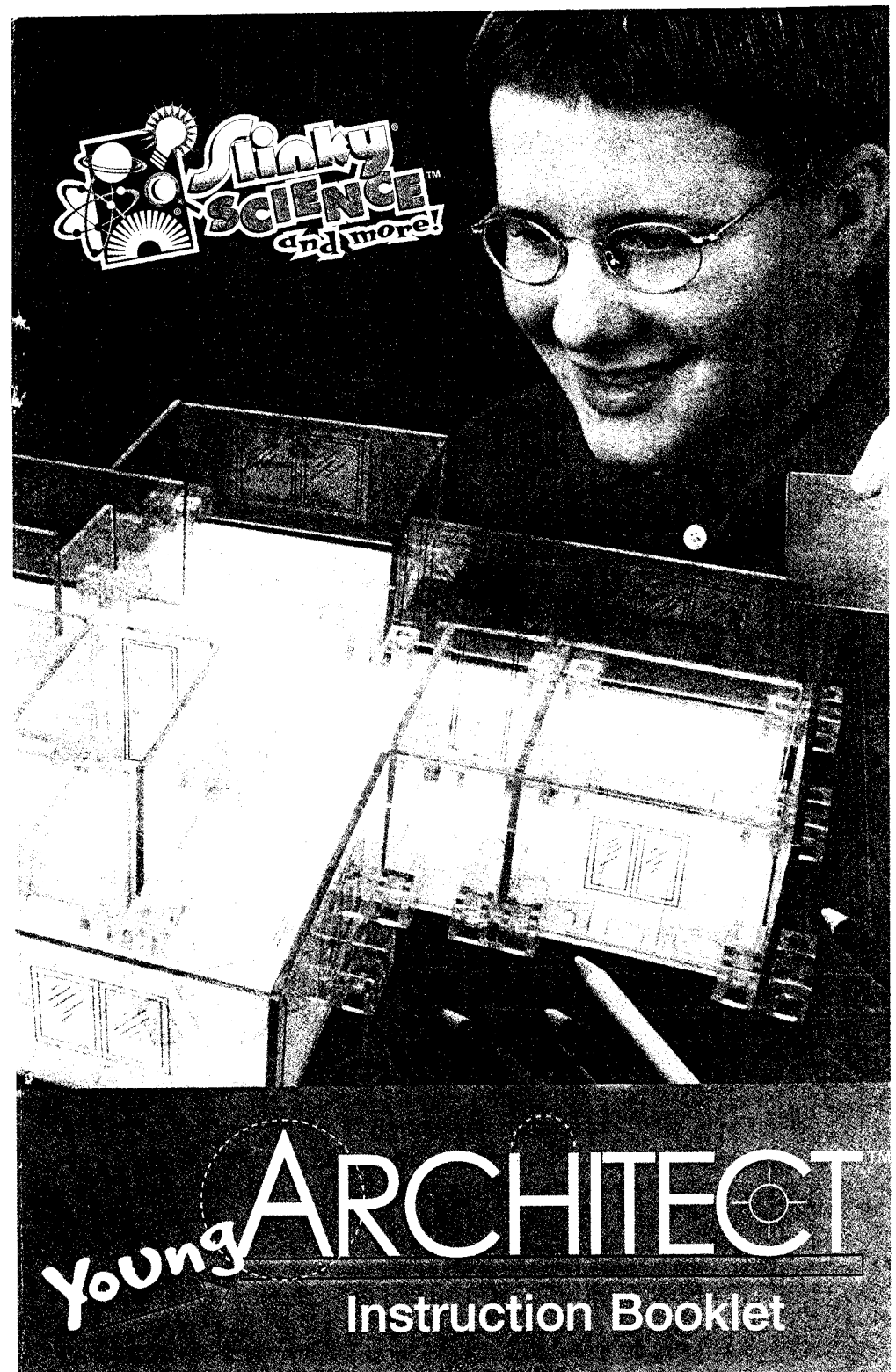

Young ARCHITECT

Instruction Booklet

What's in your set?

Your Young Architect set should include all of the following:

- 9 room templates (6 large, 3 small)
- 6 large pieces of tracing paper
- 3 furniture guides
- acrylic walls and blocks
- 1 sheet of peel and stick doors and windows
- 1 18" x 24" acrylic work mat
- 4 colored pencils

From home you will need:

- A #2 pencil (or a pencil that will not smear) with an eraser
- A good imagination!

A Word about Floorplans

Architects draw floorplans in "plan view." Plan view means that you are looking directly down on the design. If you were suspended from the ceiling, the room and furniture would look like a "plan view" design. All of the room sizes and furniture in your Young Architect set are in plan view, 1/4" scale. This means that each 1/4" is equal to one foot. For example, if you measure a room template that is 3" x 4", the room would measure 12' x 16'.

Before You Begin

First peel off the plastic protector from the acrylic work mat so that your tracing paper lies flat and smooth. Then cut out all of the doors and windows from the "Doors and Windows" sheet as indicated along the dotted lines with scissors.

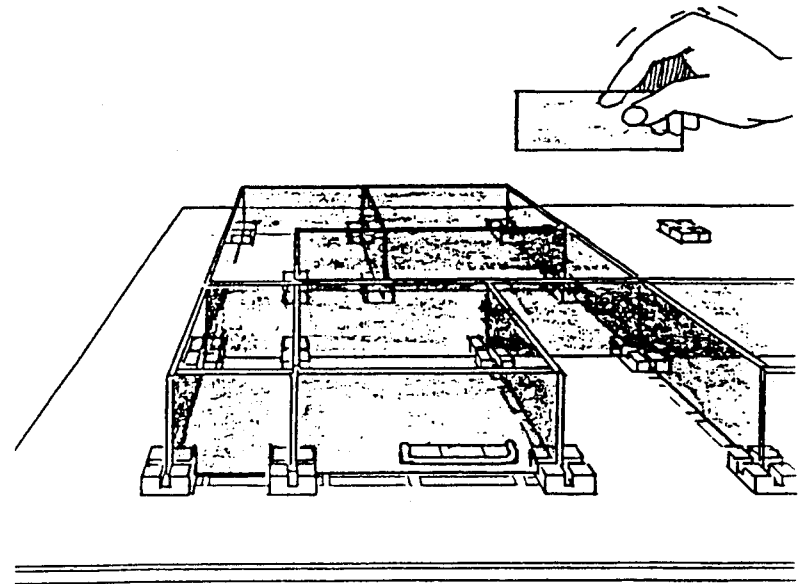

Tips: Be creative! Design rooms of all shapes and sizes (although you must keep them square so that the clear acrylic walls will fit). Try and build a 3-story mansion using 3 different sheets of paper!

The large sheets of paper are just regular sheets of tracing paper that you can find in most art supply stores, so it's easy to get more when you run out!

Building Your Design

Place the cornerblocks on all corners and intersecting walls. Then place the walls inside the cornerblocks. You may have to use varying wall sizes or combine two or more different size walls to fit the walls in your drawing.

To add doors and windows, peel the white backing paper off of each door and window (that you cut out at the beginning) and place each door and window in the appropriate places.

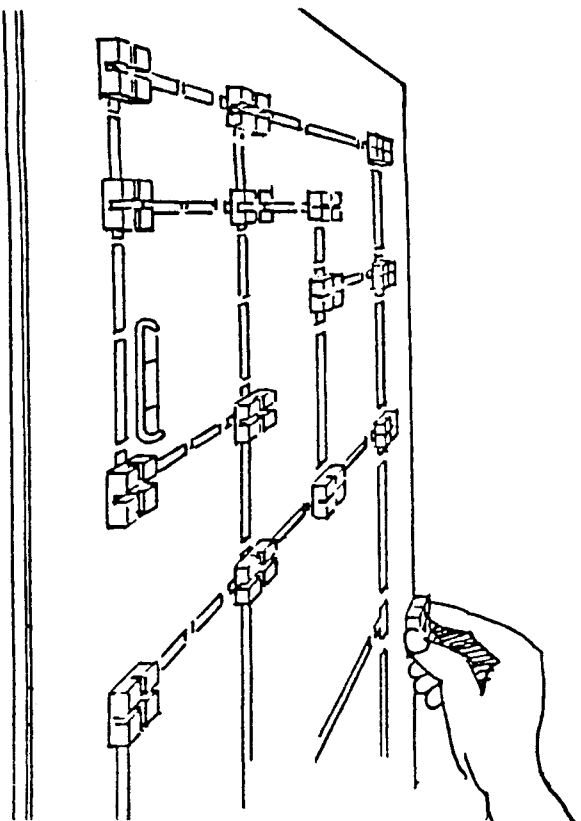

Designing a Floorplan

Place a large piece of tracing paper on your clear acrylic work mat (after peeling the protective sheets off of both sides of the acrylic work mat). Then, on a table or floor, lay out your room templates until you have a basic idea of what you want your house to look like.

When you have your final design laid out, put your templates on top of the tracing paper starting from the left side of your design and moving to the right side. When laying out templates and joining rooms, overlay the walls so that the walls are a single thickness.

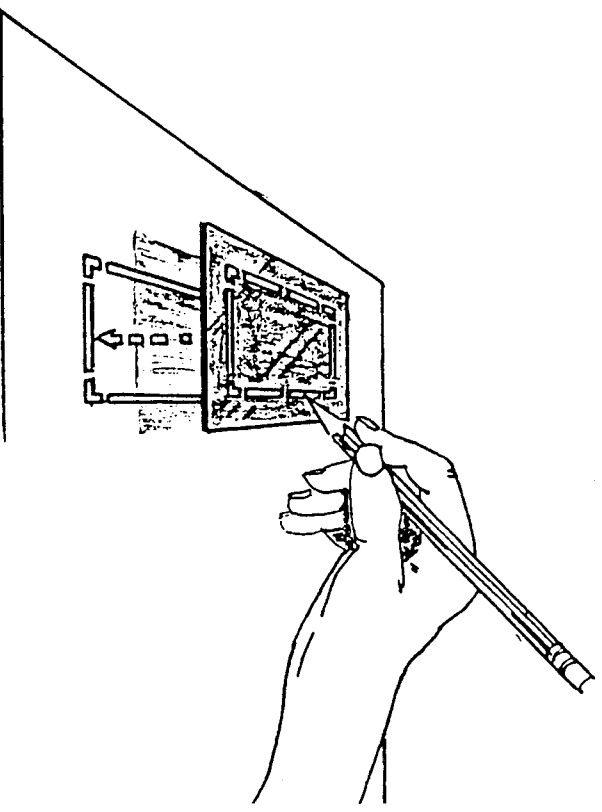

Then insert a pencil into the die-cut slots that you punched out, and draw your rooms onto the tracing paper. **TIP:** Use a #2 pencil or any pencil that won't smear when you are tracing your rooms and your furniture (most pencils that are made are #2 pencils, so you should have one). Also be sure that it has a good eraser, as it will be easier to make changes to your design and won't leave any unwanted pencil marks. When you are finished drawing your floorplan, you can add rooms by placing any template on the outside edge of an existing room (making sure to overlap walls) and tracing around it. You can even erase walls to make rooms bigger or add walls to make rooms smaller. Remember: this is your plan, so get as creative as you can!

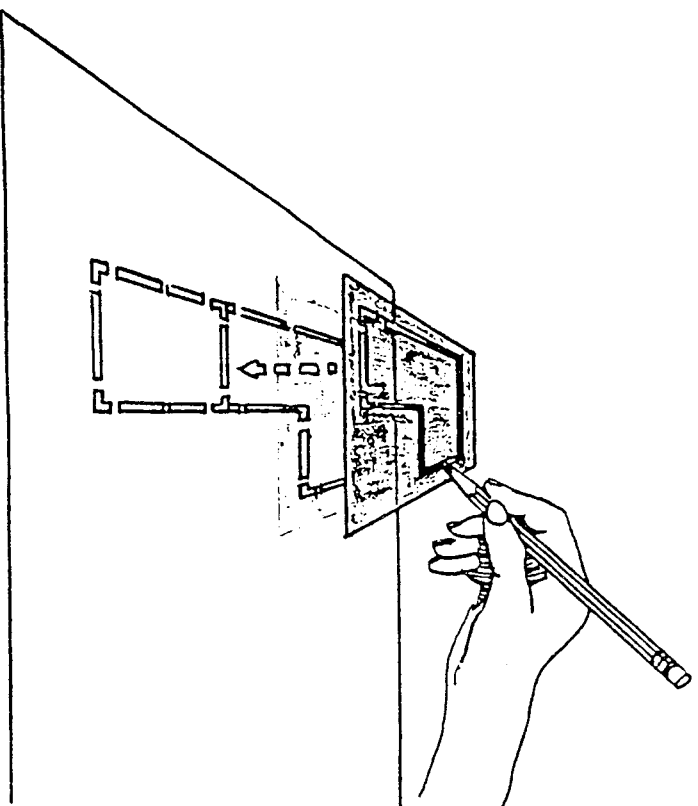

Furnishing the Floorplan

Add furniture and door swings to each room by slipping any of the furniture-tracing guides under the plan. Arrange the furniture guide so that the desired piece of furniture or door swing is where you want it. Then trace it on to your floorplan. When your plan is completely finished, use colored pencils to color the furniture.

